

# ***FLUID MANAGEMENT***

Instructions manual  
for the Dispenser

Type:  
BT-Tintmaster



Illustrated model:  
BT-16  
1860330-eng



We, **Fluid Management Europe B.V.**  
A Unit of IDEX Corporation  
Hub van Doorneweg 31  
2171 KZ SASSENHEIM

herewith declare, on our own responsibility, that the products

**HA-xs/s/m/l**  
**BT-Tintmaster**

which this declaration refers to, are in conformity with the following standard(s) or other such specifications

NEN-EN 292-1, 1994  
NEN-EN 292-2, 1996  
NEN-EN 418  
prNEN-EN 1050, 1993  
NEN 2446, December 1976  
NEN 3544, May 1984  
EN 50081-1, 1992  
EN 50082-1, 1992  
EN 55024-2  
EN 55024-4  
NEN-EN 60204-1, 1995  
EN 61000-3-2, 1995

according to the conditions of the Machinery-, Low Voltage- and the EMC-directive.



The Netherlands  
Sassenheim, 5-5-1999

W. Van Westerop  
Vice President Manufacturing  
Fluid Management Europe B.V.  
A Unit of IDEX Corporation

---

1. General	page 3
2. Guarantee conditions	page 4
3. Safety instructions and warnings	page 5
4. Positioning/Installing the machine	
4.1 Conditions for correct positioning	page 6
4.2 Installing the machine	
4.2.1 Preparation	
4.2.2 Removing the floor model from the pallet	page 7
4.3 Mounting the monitor stand and installing the computer system	page 8
4.3.1 Mounting the monitor stand	
4.3.2 Mounting the mouse and printer stand	
4.3.3 Installing the computer system	page 9
5. Operation	page 10
5.1 Brief overview and function of the operating elements	
5.2 Starting the machine	page 11
5.2.1 Preparing the machine for use for the first time	
5.2.2 Preparing the machine at the start of the day	
6. Maintenance	page 12
6.1 Maintenance instructions	
6.2 Maintenance to be carried out by the operator	
6.3 Troubleshooting	page 13
6.4 Service/Service department	page 14
7. Machine identification data	page 15
7.1 Machine plate data	
7.2 Pictures of the machine parts	
7.2.1 Canister and dispensing pump	page 16
7.2.2 Mains connection	page 17
7.2.3 Power unit and sensor position	page 18
8. Specifications	page 19

By selecting a Fluid Management Color Dispenser you have opted for a product which is the result of intensive research in the field of high-tech color dispensing equipment. Top quality components, craftsmanship and modern ergonomic design all serve to guarantee a long service life and a high degree of user friendliness.

The equipment complies with Council Directives 89/392/EEC on machines, 89/336/EEC on electromagnetic compatibility and 73/32/EEC on electrical material intended for use within given voltage limits, as enacted by the Council of Ministers of the European Community. The equipment is furnished with a CE mark.

Keep this manual in a safe place.

In these guarantee conditions, 'FM' is understood to mean Fluid Management Europe.

The guarantee conditions incorporated into FM's general conditions of sale are summarized as follows (for free general conditions you can apply to FM):

1. FM guarantees the proper operation of any goods which it supplies, for a period of one year, except where a breakdown is the result of normal wear and tear. The cost of any inspection activities carried out by FM, with the aim of establishing whether or not a breakdown is covered by the guarantee, will be reimbursed by the other party if it transpires that the breakdown is not covered by the guarantee. If it transpires that a breakdown is covered by the guarantee, then FM will supply identical or equivalent goods under the conditions referred to in point 6 of the general conditions of sale. The guarantee obligation described in this article only applies if the goods supplied by FM have been used in accordance with the manual. Time spent on guarantee-related activities, including travel time, travel costs and accommodation costs, are charged at current rates.
2. In contrast to the above, FM will not be held to any guarantee obligation if
  - a) repairs have been carried out, or attempted, by the other party or a third party, unless FM had previously declined to repair the goods for a fair price;
  - b) FM demonstrates that the defect did not emerge during testing;
  - c) the other party fails to inform FM of the defect immediately, if possible either by letter and/or by fax, providing full, accurate details and/or has failed to comply fully with FM's instructions;
  - d) the other party has failed to use or treat the goods properly or in accordance with FM's instructions;
  - e) the damage has been caused by incidents, beyond FM's supervision, which have occurred either during transport or installation.
3. In the following text, the expression "Software" will be understood to mean the standard computer software supplied by FM to the other party, recorded on a computer-readable storage medium, plus the accompanying documentation (Software Manual) and including any improved and/or new versions supplied. The expression "processing unit" (PU) is understood to mean the machine for which and with which the Software is supplied, and which is the sole machine on which the Software may be used.
4. The other party is authorized to copy the Software either in its entirety, or in part, (up to a maximum of 2 copies) for purposes of internal security. These copies will be furnished with the same marks, designations relating to copyright and other registration numbers as the original version of the Software.
5. The other party will neither amend, translate, decompile nor adapt the Software, nor convert it into source code, without express written permission from FM. If the other party so requests, FM will provide that party with the information required to render the Software interoperable with other software.
6. In the event that the PU experiences a breakdown, the other party may use the software on another processing unit until the PU is again operational. The other party will inform FM of this within 5 days.
7. If it is a requirement that the Software be definitively transferred from the PU to another processing unit then the other party shall request permission from FM, which will not withhold such permission on unreasonable grounds.

Before installing the equipment and setting it in operation, read the instructions for use carefully. This is safer for you and it prevents needless damage to the machine.

The manufacturer accepts no liability if the instructions below are not followed:

- If a machine has been damaged (during transport, for example), do not attempt to set it in operation. When in doubt, first contact either the Service department (see section 6.4) or your supplier.
- The equipment should be positioned and connected up in strict accordance with the installation instructions.
- All local safety regulations and ordinances should be observed.
- The machine may be connected only to a 230 V / 50 Hz / 60 Hz earthed wall socket installed in accordance with the regulations.
- Users should see to it that the machine is kept in good condition. Defective components should be replaced.
- In order to prevent physical injury, the doors should be closed and the panelling fitted during normal use.
- Keep the keys of the machine in a special, safe place.
- All service activities (other than routine adjustments) may only be carried out by qualified technicians. See to it that the mains lead is always kept unplugged while repairs are being carried out.
- The standard equipment is only suitable for dispensing water-based color pastes into tins of basic paint. The use of other solvents may damage the sealing rings and cause the equipment to leak. The equipment can, however, be adapted for use with other solvents.
- Because of the design of the valve, a nozzle drill may **never** be used. Cleaning is done by running the cleaning program.

#### 4.1 Conditions for correct positioning

Make sure that the following requirements are met when positioning the machine:

- Place the machine on a stable, flat surface, and make sure that it is level.
- Any dry, well ventilated place is suitable. The machine should preferably not be placed in the sun or near a radiator or other source of heat, since this can cause the pastes to dry out.
- Maintain a constant ambient temperature of approximately 18°C to prevent viscosity changes in the pastes.
- Make sure that the machine is connected only to a 230 V / 50 Hz / 60 Hz earthed wall socket.

#### 4.2 Installing the machine

##### 4.2.1 Preparation

Note: Tools and fastenings are supplied with the machine. They include spanners, cable connectors, bolts, washers etc.

- Remove the plastic bag of lids and the installation kit from the lift table. Take the spanner out of the installation kit and remove the side panel on the left side of the machine.
- Remove the fastening bolts attaching the machine to the pallet (see figure 1, number 1).
- Turn the adjustable feet at the front of the machine(see figure 1, number 2) all the way up.
- Remove the wooden slat from under the machine.

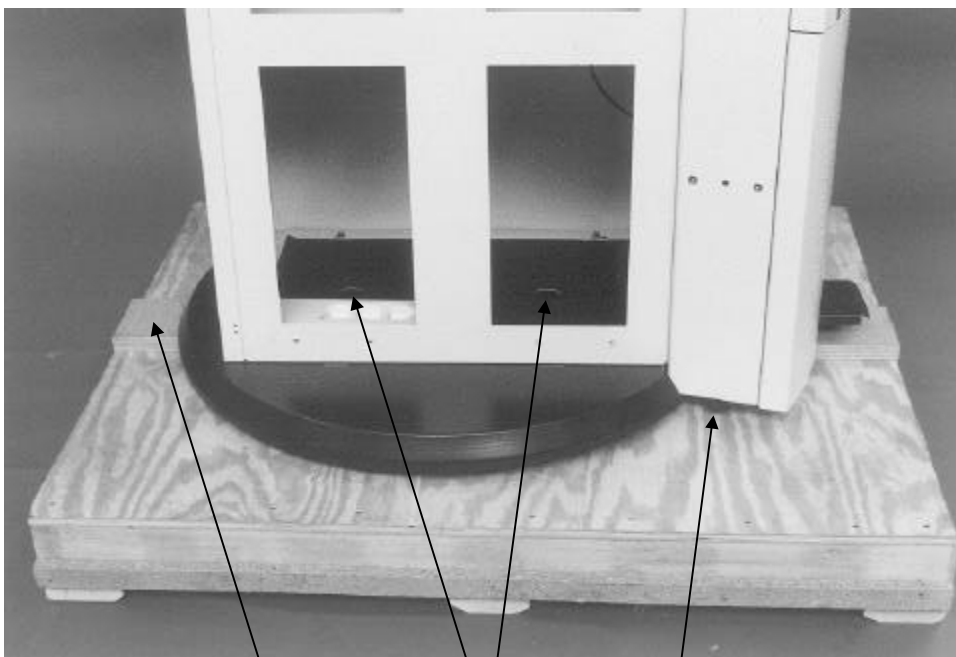

figure 1

3

1

2

### 4.2.2 Removing the machine from the pallet

- Lift the machine slightly with the handles on the back of the machine and, with two people behind the machine, pull the machine backwards (see figure 2).
- Carefully lower the back to the floor (figure 3).
- Carefully tip the machine slightly further so that the front is clear of the pallet.
- Slide the pallet away from under the machine and lower the machine carefully (figure 4).
- You can now wheel the machine to where you want it by lifting it by the handles on the back.
- Lastly, unscrew the adjustment feet at the front and back so that the machine is no longer resting on the wheels, and is stable and level. (There are also adjustment feet at the back).

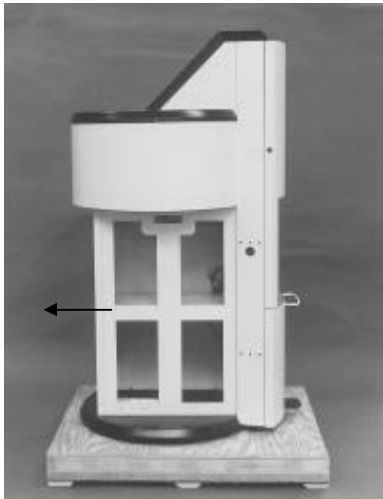

figure 2



figure 3



figure 4

### 4.3 Mounting the monitor stand and installing the computer system

4.3.1 Mounting the monitor stand (**optional** on the BT) which can be mounted on the left **or** right of the machine.

- Turn the four fastening bolts with washers and spring washers two turns in the fastening holes in the base, as shown in figure 6.
- Drop the brackets of the monitor support over the bolts on the machine and tighten the bolts (spanner 10).
- Adjust the monitor brackets (see figure 7) to the correct size and tighten them.
- Remove the cover plates.

4.3.2 Mounting the mouse and printer stand (**optional** on the BT)

Attach the mouse and printer stand under the monitor stand with the bolts supplied (see figure 6/7).

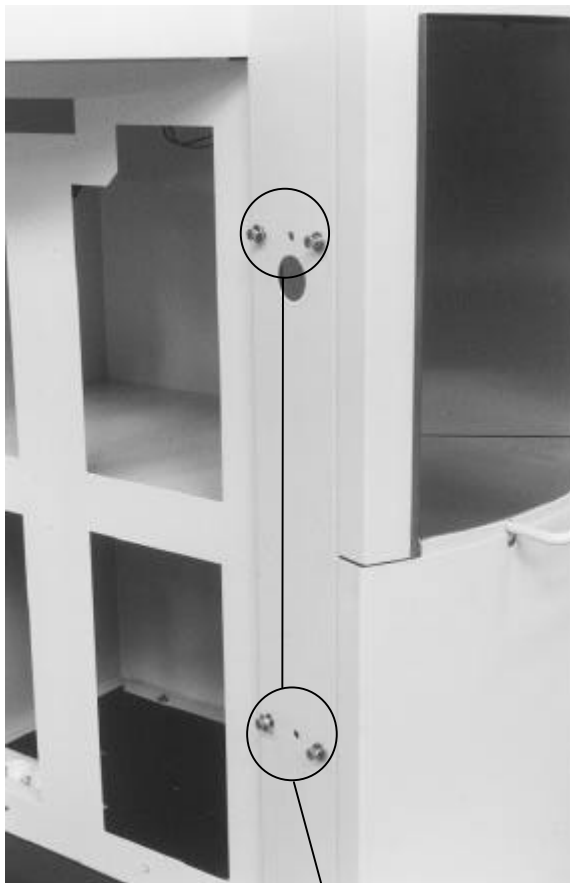

figure 6

fastening bolts

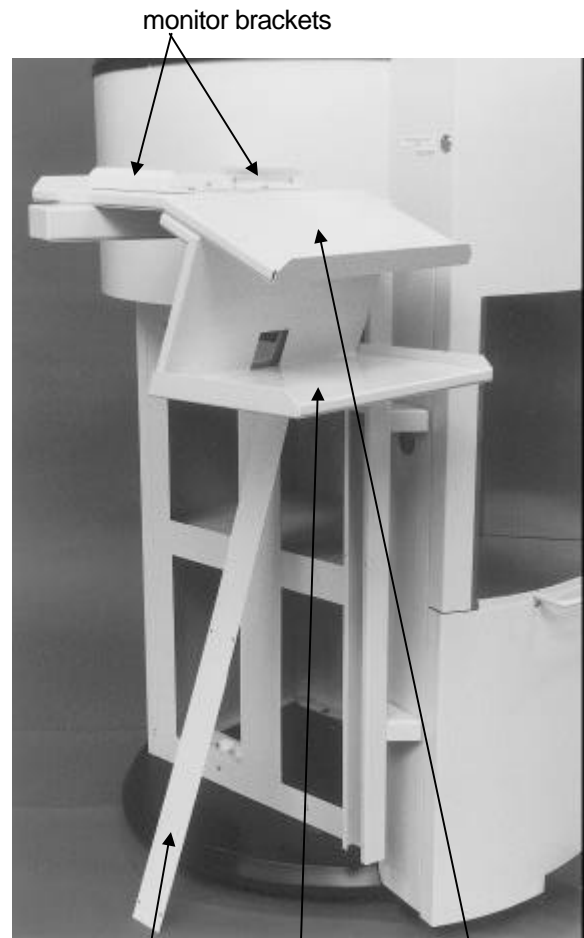

figure 7

cover plate  
(2x)

mouse /  
printer stand

monitor /  
keyboard arm

**Before proceeding any further :**

Take the installation manual out of the computer packaging and look up the connection information. This provides a clear description of all computer cables and plugs and the correct way to connect them.

**4.3.3 Installing the computer system (BT with optional monitor stand & mouse/printer stand where applicable)**

- Position the keyboard (2), the monitor (3) and the computer (4), (and the mouse (5) and label printer (6) where applicable) as shown in figure 8.
- Feed the keyboard and monitor cables through the monitor stand into the machine (and the mouse and label printer cables where applicable). See figure 9. Make sure they are running the right way!
- Connect the 9-pin serial connector from the powerunit to COM B of the computer.
- Attach the cover plates to the monitor stand.
- Bundle any loose pieces of cable with the cable ties supplied.
- Plug the computer and monitor plugs into the internal socket and switch them on with their on/off switches

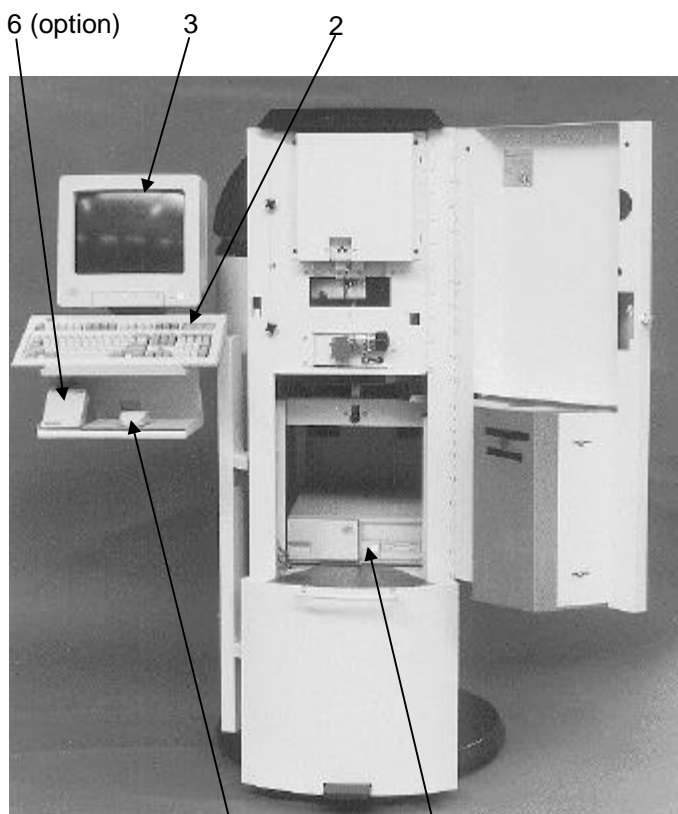

figure 8

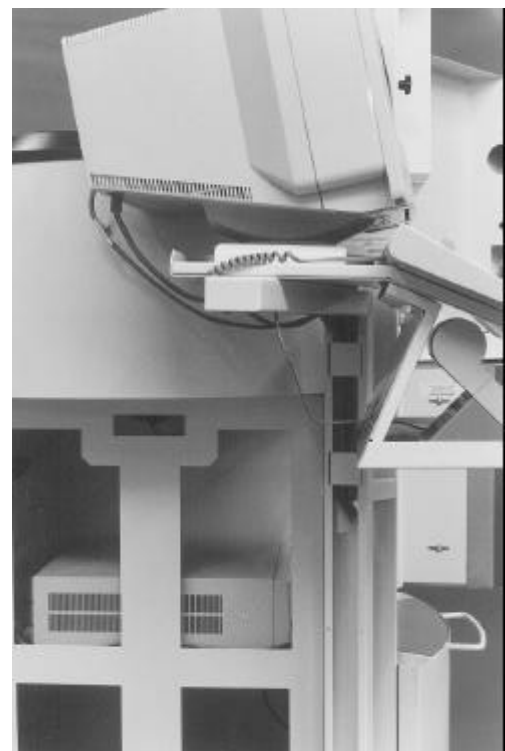

figure 9

5 (option)

4

### 5.1 Brief overview and function of the operating elements

See figure 10 (elements shown with a dotted outline are located inside the machine).

- |                                |   |
|--------------------------------|---|
| 1. Main switch (red)           | ⇒ Switching the machine on and off            |
| 2. Keyboard (various versions) | ⇒ Controlling the process                     |
| 3. Monitor / Flat screen       | ⇒ Monitoring and coordinating the process     |
| 4. Computer                    | ⇒ Input and output control unit               |
| 5. Mouse ☆                     | ⇒ Controlling the process                     |
| 6. Printer ☆                   | ⇒ Printing label for dispensed paint colour   |
| 7. Cleaning brush/Brush tray   | ⇒ Cleaning the nozzles                        |
| 8. Lift table unlocking pedal  | ⇒ Unlocking the lift table                    |
| 9. Can sensor                  | ⇒ Positioning cans at correct filling height  |
| 10. Flap (left and right)      | ⇒ Closing the access opening to the canisters |
| 11. Thermostat ☆               | ⇒ Adjusting temperature of heating element    |
| 12. Computer switch (green)    | ⇒ Switching the computer on and off           |

☆ = Optional

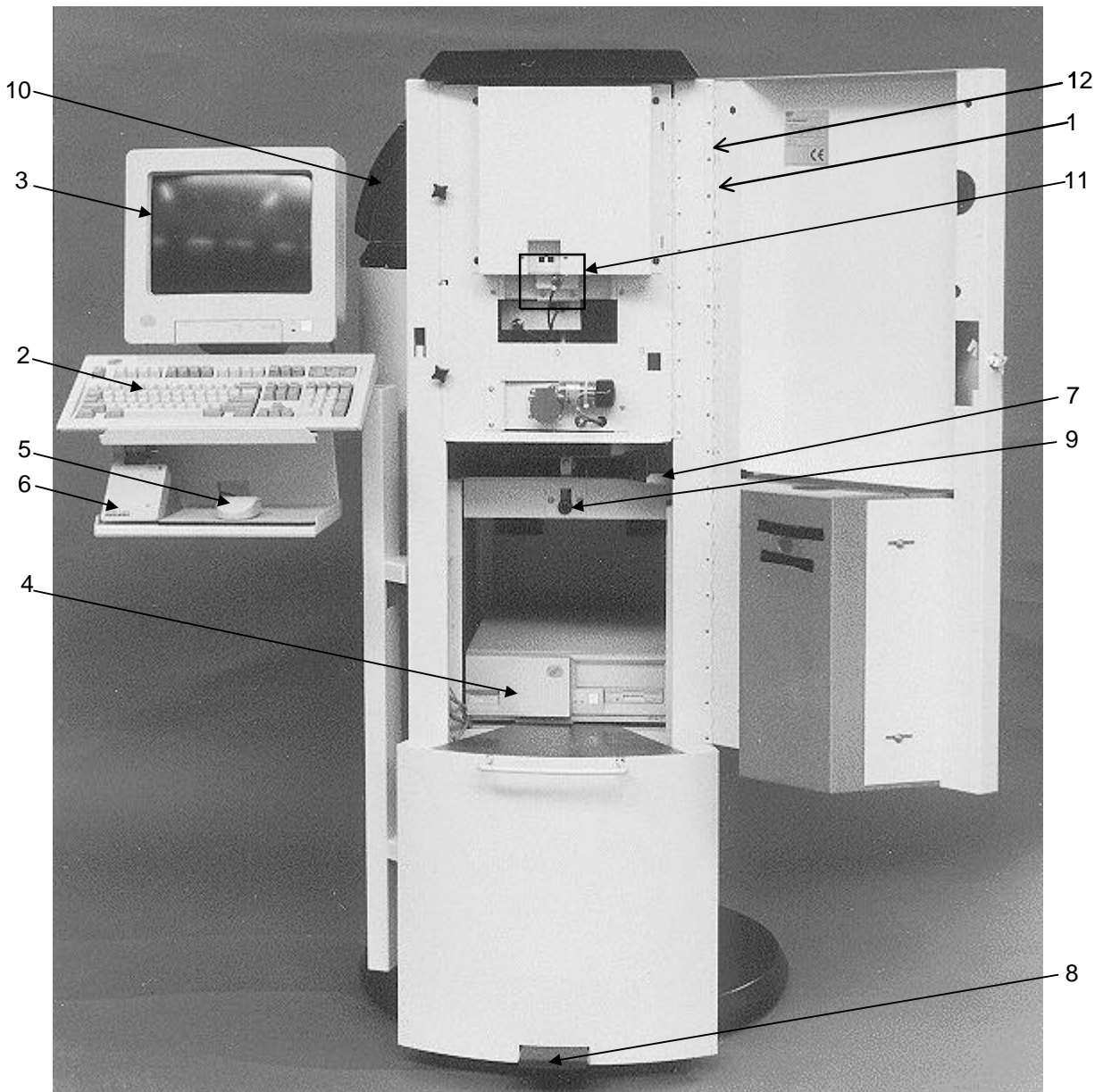

figur 10

## 5.2 Starting the machine

### 5.2.1 Preparing the machine for use for the first time

1. Turn the **red** main switch (see figure 10, number 1) to position <l> .  
*You are advised to leave this switch turned on at all times. This is necessary for the automatic stirring system. It also reduces wear on the machine and the computer system.*  
Then turn also the **green** switch (see figure 10, number 12) to position <l>. Now the computer is turned on. Switch the computer off at the end of the day.
2. Open the door of the machine and remove the brush tray. Fill the brush tray with water or a diluted detergent (under no circumstances use a solvent!) up to the level mark. Replace the tray in the correct position and close the door.
3. Use the software to set the stirring interval\*.
4. Adjust the thermostat if installed (see the instructions for use supplied with the thermostat).
5. Fill the canisters with paste up to the indicated maximum level\* by opening the flap and removing the lid of the canister. The canister can now be filled to the top of the upper stirrer. Make sure that the piston rod remains at the same height.
6. Ask your paste supplier for the stirring data for the pastes. It may be necessary to stir the pastes. Stirring can be started with the aid of the software\*.
7. Now you can start the morning program\*.

### 5.2.2 Preparing the machine at the start of the day

1. Open the door of the machine and remove the brush tray. Fill the brush tray with water or a diluted detergent (under no circumstances use a solvent!) up to the level mark. Replace the tray in the correct position and close the door.
2. If necessary, top up the canisters to the maximum level. When you do this it may be necessary to stir the pastes (ask your paste supplier).
3. Start the morning program\*.

The machine is now ready for the day.

---

\* see software manual

### 6.1 Maintenance instructions

Always remove the power cord from the mains socket before commencing any maintenance work on the machine.

1. Servicing and repairs may only be carried out by qualified personnel
2. Use good quality, appropriate tools only.
3. Use original Fluid Management parts only.
4. Before the machine is made available for use after service, all settings must be checked to ensure that they are correct and the operating and safety systems must be checked to ensure that they are functioning properly.

### 6.2 Maintenance to be carried out by the operator

#### *Daily :*

1. Clean the cleaning brush and replace the cleaning fluid in the brush tray (see 5.2.1, point 2).
2. Check nozzles for blockage by means of the morning program\*. If there is a blockage, contact the Service Department (see 6.4).

#### *Weekly :*

1. Remove spilt paste from the turntable and lift table.
2. Check the content of the canisters and top up to the indicated level. Update the content data stored in the computer\*.

#### *Monthly :*

1. Clean the computer cavity, the computer can be affected by dust.
2. Check the valves, valve housings and pumps for leaks..
3. Check that the valve handle is still in the correct position.

---









\* see software manual

### 6.3 Troubleshooting

Before calling in the Service Department, check whether you can solve the problem yourself. If you cannot, call the Service Department for advice (see 6.4). Have the model number and serial number to hand. They can be found on the nameplate on the machine (see 7.1).

Use the chart of Problem, Cause and Action below to judge whether you can solve a problem yourself or whether you will need to call in the Service Department. The  symbol means that the Service Department must be called.

This chart does not include any of the malfunctions which are reported in an error message by the software. In the event of a malfunction, these messages and possible solutions are displayed on the monitor.

Problem	Cause	Action
Valve leaks through the outlet opening	Valve is defective	Replace valve 
Canister connection leaks around the suction point	Worn O-ring(s)	Replace O-ring(s) 
Air is being fed together with the paste	6. Air in the pump 7. Canister is empty 8. Piston is defective 9. Valve handle spring broken	1. Bleed the pump 2. Add paste 3.  4. 
(New) software is not working	1. Diskette is damaged 2. Wrong data 3. Program not loaded correctly	1. Request new diskette 2.  3. Reload programm
Sensors are not working	5. Main switch is off 6. Cables to power unit are loose 7. No mains power 8. Fuse has blown	1. Turn main switch to position < > 2. Remove plugs from socket, check cables 3. Check if there is mains power 4. Remove plug from socket, replace fuse
No power from power unit	1. Main switch is off 2. Cables to power unit are loose 3. Fuse has blown	1. Turn main switch to position < > 2. Remove plugs from socket, check cables 3. Remove plug from socket, replace fuse
There is no 230 V	5. Main switch is off 6. No power to (internal) socket 7. Fuse has blown	1. Turn main switch to position < > 2. Check electrical wiring 3. Remove plug from socket, replace fuse
Colours are difficult to reproduce	1. Mechanisms are dirty 2. Quality fluctuations in paste supplied 3. One or more pastes have thickened 4. Leaks around piston(s) 5. Turntable in wrong position 6. Valve handle spring is broken	1. Clean and oil 2. Contact paste supplier 3. Replace paste(s) 4. Replace piston(s)  5. Press reset and test (see fig. 11) 6. 
Poor monitor picture, or no picture	6. Monitor is switched off 7. Loose cable(s) 8. Picture set too dark 9. Monitor malfunctioning	1. Switch monitor on 2. Check cables 3. Adjust picture correctly 4. 

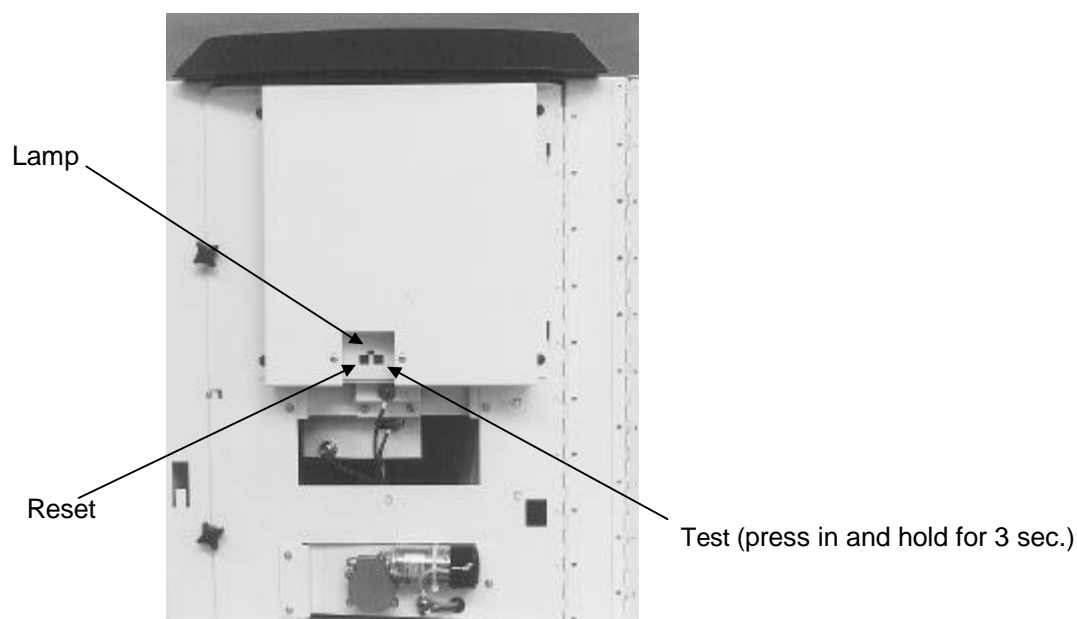
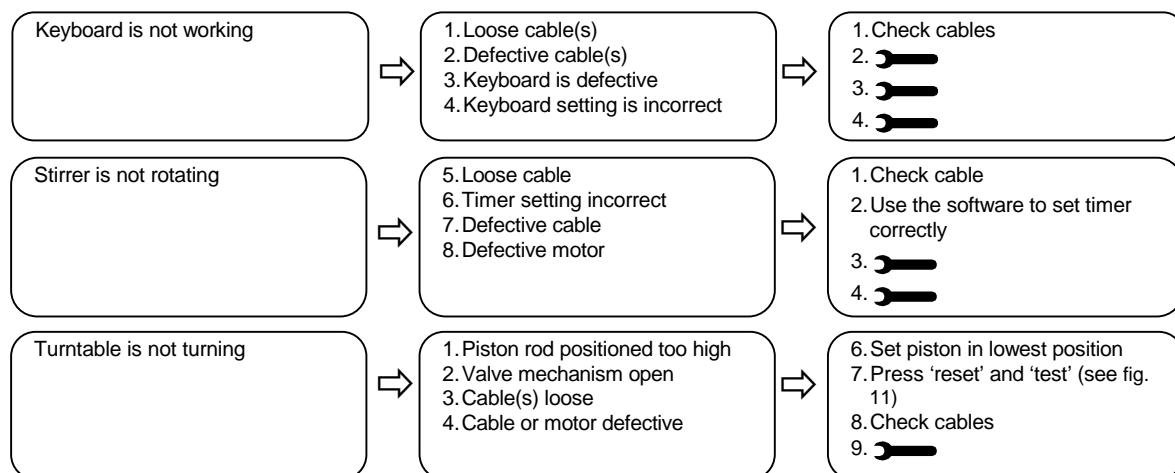

figure 11

Press the reset button if your machine is not working properly and a red light comes on just above the reset button. A green lamp will then light up.

Now press the test button and hold it in for at least 3 seconds. The machine will test all components and can then be used again.

Contact the manufacturer if this procedure does not give the desired result.

#### 6.4 Service/Service department

If necessary, you can get in touch with your supplier or the local service department, or contact the manufacturer directly. If you contact the manufacturer, make sure that you have the model number and serial number to hand. They can be found on the nameplate on the machine (see 7.1).

Fluid Management Europe  
 P.O. Box 220  
 2170 AE Sassenheim, Netherlands  
 Hub van Doorneweg 31  
 2171 KZ Sassenheim, Netherlands  
 Tel. : 0031 252 240800  
 Fax : 0031 252 240882 (service)  
       0031 252 240880 (general)

### 7.1 Machine plate data

To reach the machine plate, first open the front door of the machine. The plate is situated on the left side of the machine in the upper left corner.



The image shows a machine identification plate for Fluid Management. It features the company logo at the top left, followed by the company name and address. Below this is a table for technical specifications, two input fields for model and serial numbers, and a CE mark in a box at the bottom right.

**FM**

---

**Fluid Management**

P.O.Box 220  
2170 AE Sassenheim, Holland

	V~	Hz	W	
Weight	kg		A	

Model nr.:  
Serial nr.:

**CE**

7.2 Pictures of the machine parts

7.2.1 Canister and dispensing pump

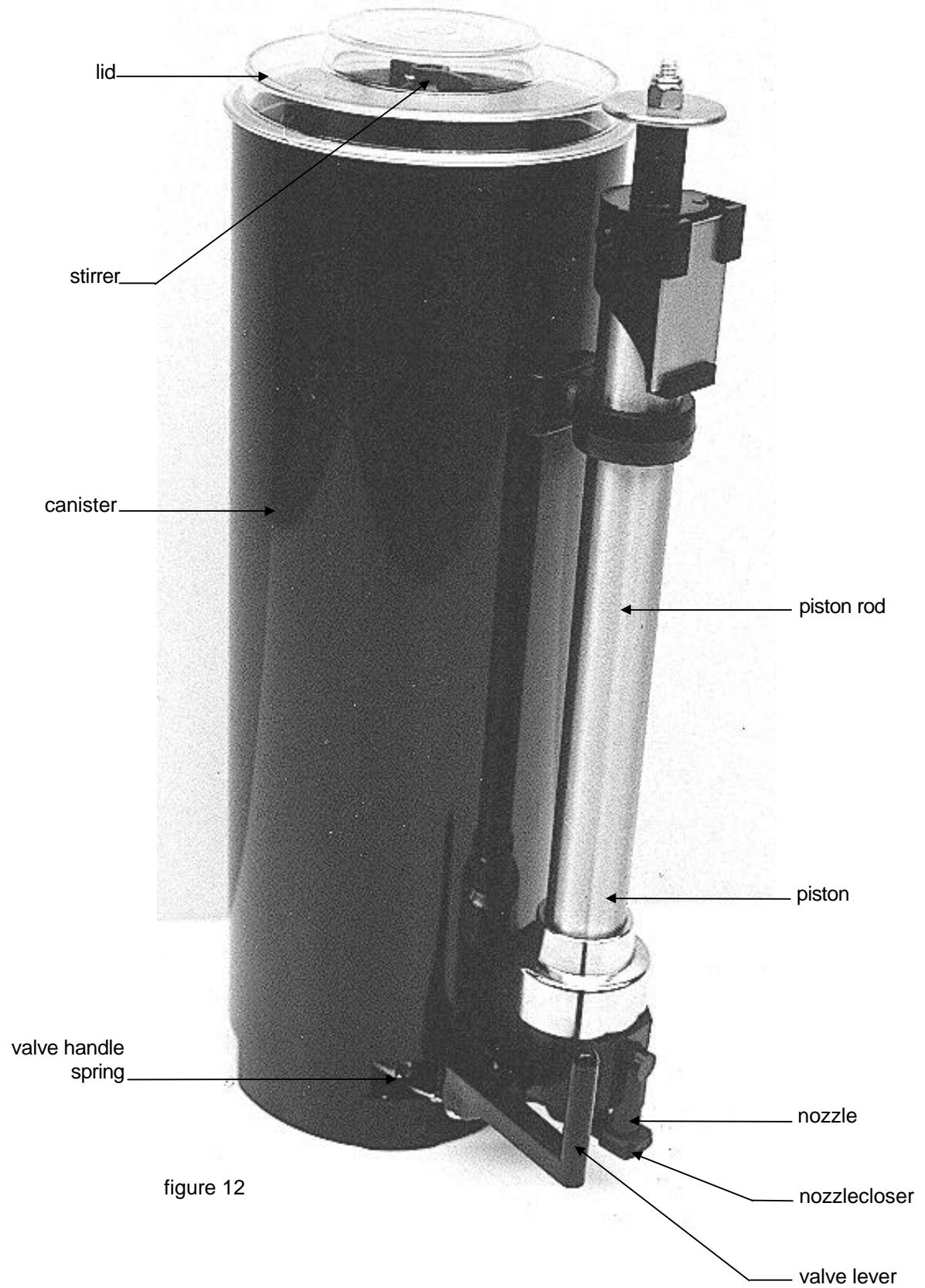

figure 12

7.2.2 Mains connection

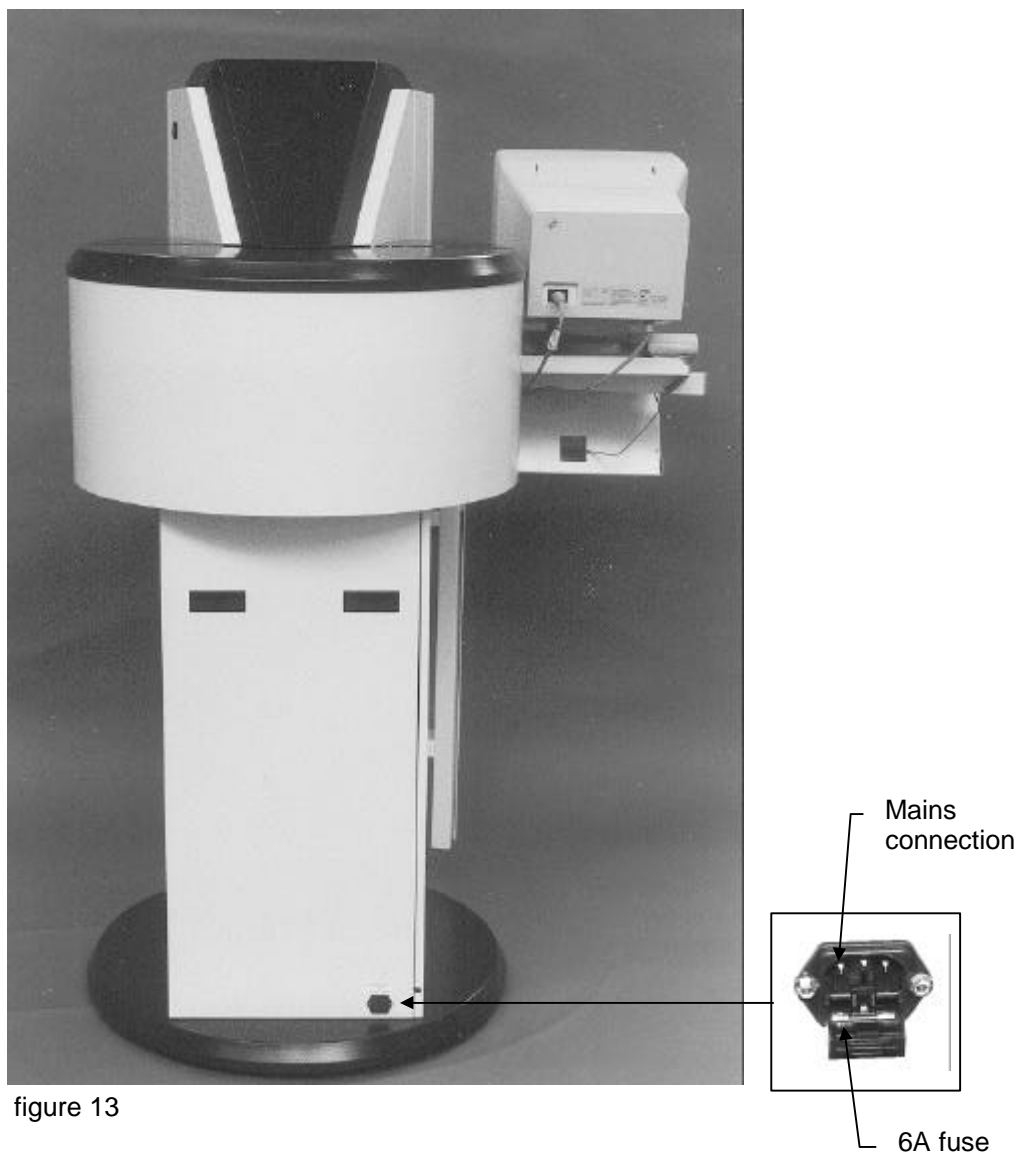

figure 13

7.2.3 Power unit and sensor position

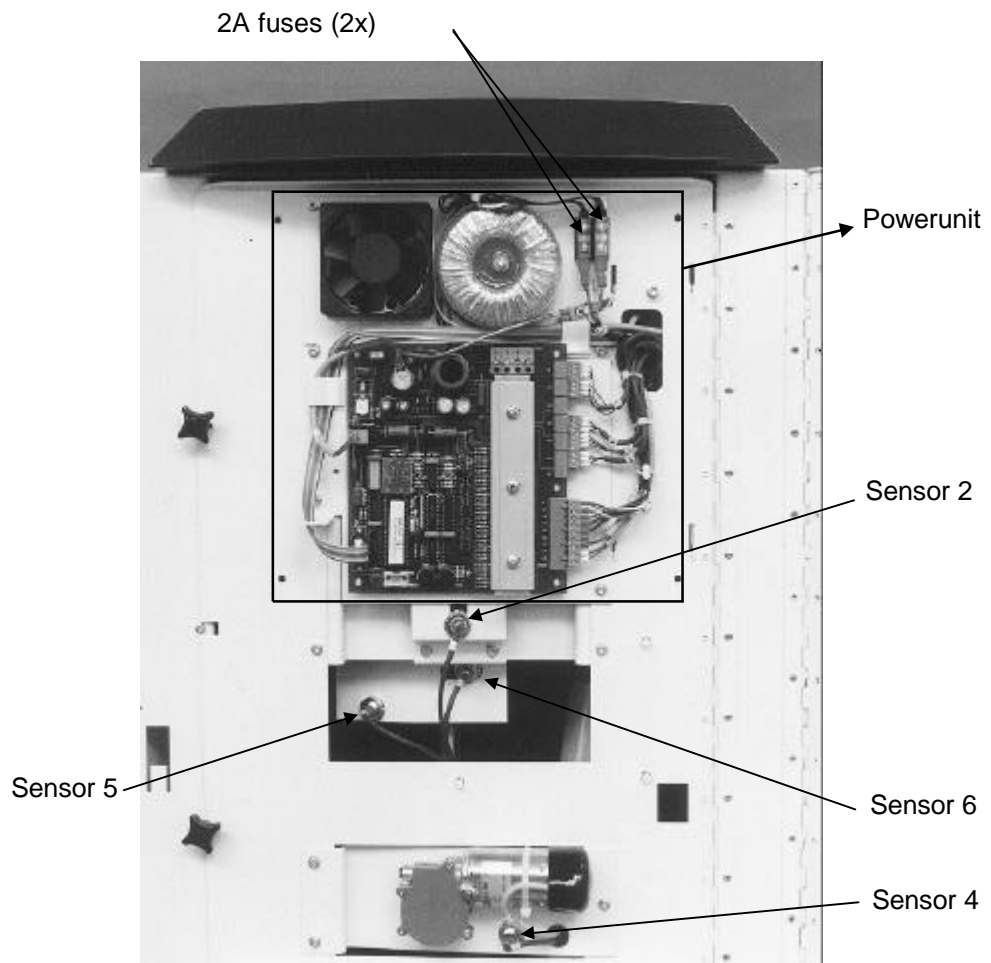

figure 14

		BT
Polymeric canisters, contents:		1,75 liter
Teflon pistons		✓
Stainless steel pumps		✓
Number of canisters		12, 14 of 16
Height		1675 mm
Width	<ul style="list-style-type: none"><li>• IBM-keyboard</li></ul>	1175
	<ul style="list-style-type: none"><li>• without keyboard</li></ul>	790mm
Weight		± 130 kg
Mains voltage		230 V ~ 50 Hz
Amperage		1,5 Ampère
Computer system		✓
A-weighted equivalent continuous sound pressure		< 70 dB(A)