

Info block:(unless specified otherwise)

PDF  DXF  DWG

Remove sharpe edges

Tool :

V - Die :

Colour :

End Product

Semi Manufactured

Rev.	Description	By	Date
------	-------------	----	------

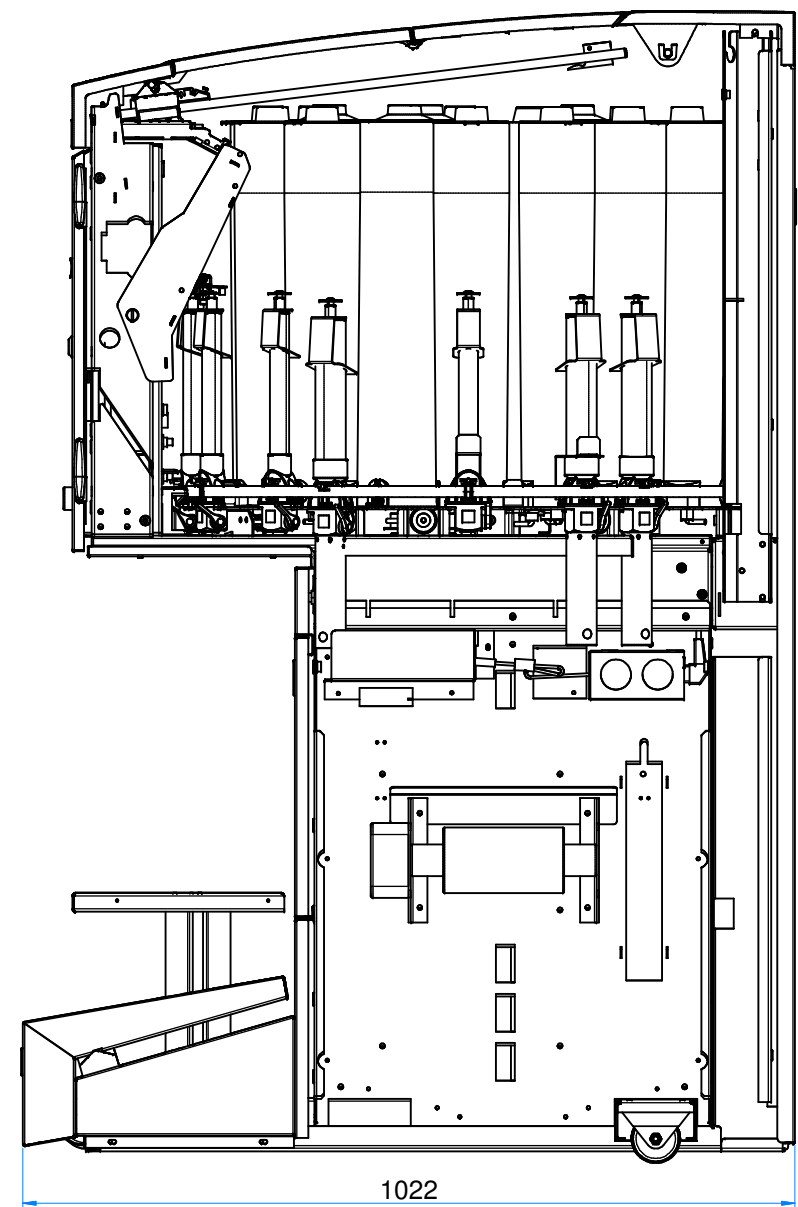
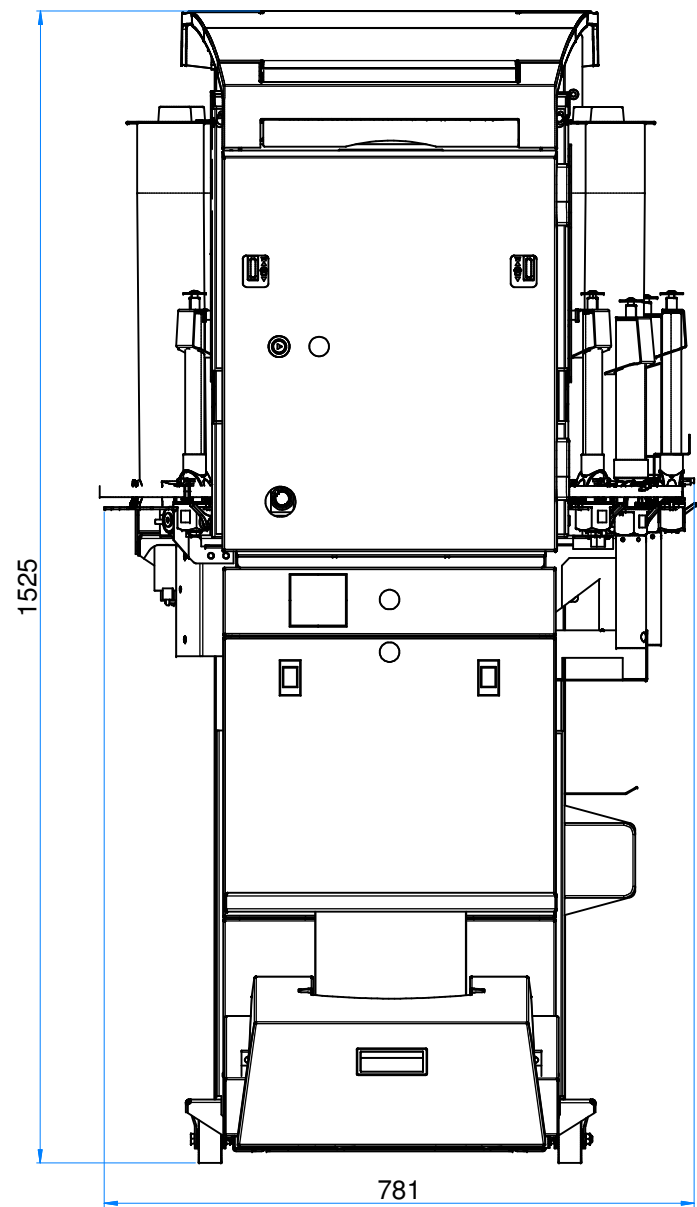

<p>ALL DIMS ACC. TO NEN-ISO 2768 M UNLESS OTHERWISE SPECIFIED</p> <p>0.5-6 ± 0.1 120-400 ± 0.5 SHORTEST SIDE 50-120 ± 20'</p> <p>6-30 ± 0.2 400-1000 ± 0.8 &lt; 10 = 1' 120-400 ± 10'</p> <p>30-120 ± 0.3 1000-2000 ± 1.2 10-50 = 30" &gt; 400 = 5'</p>	<p>CONFIDENTIAL PROPRIETARY MATERIAL. All design, reproduction, manufacturing, use &amp; sales rights of items shown here on or of articles fabricated therefrom are expressly reserved by FAST &amp; FLUID MANAGEMENT</p>		<p>DRAWING ACCORDING TO</p> <p>NEN-ISO 1101 NEN-ISO 406 NEN 3634</p>	<p>Projection</p>
	<p>Size: A2</p>	<p>Unit : mm</p>	<p>Date :28-7-2004</p>	
<p>Project :</p>	<p>Drawn :</p>	<p>Assembly partnr:</p>		
<p>Dim. :</p>	<p>Material :</p>	<p>Partnr: 4901(HA400)</p>		
<p>Name:</p>				

**FAST & FLUID MANAGEMENT**  
**THE NETHERLANDS**  
 A Unit of IDEX Corporation  
 P.O. Box 220 | 2170 AE Sassenheim  
 Huis van Doornweg 51 | 2171 KZ Sassenheim  
 Telephone +31 (0)252 240 800  
 Fax +31(0)252 240 880 | www.fast-fluid.com