

Info block:(unless specified otherwise)

PDF DXF DWG

Remove sharpe edges

Tool :

V - Die :

Colour :

End Product

Semi Manufactured

Rev.	Description	By	Date
------	-------------	----	------

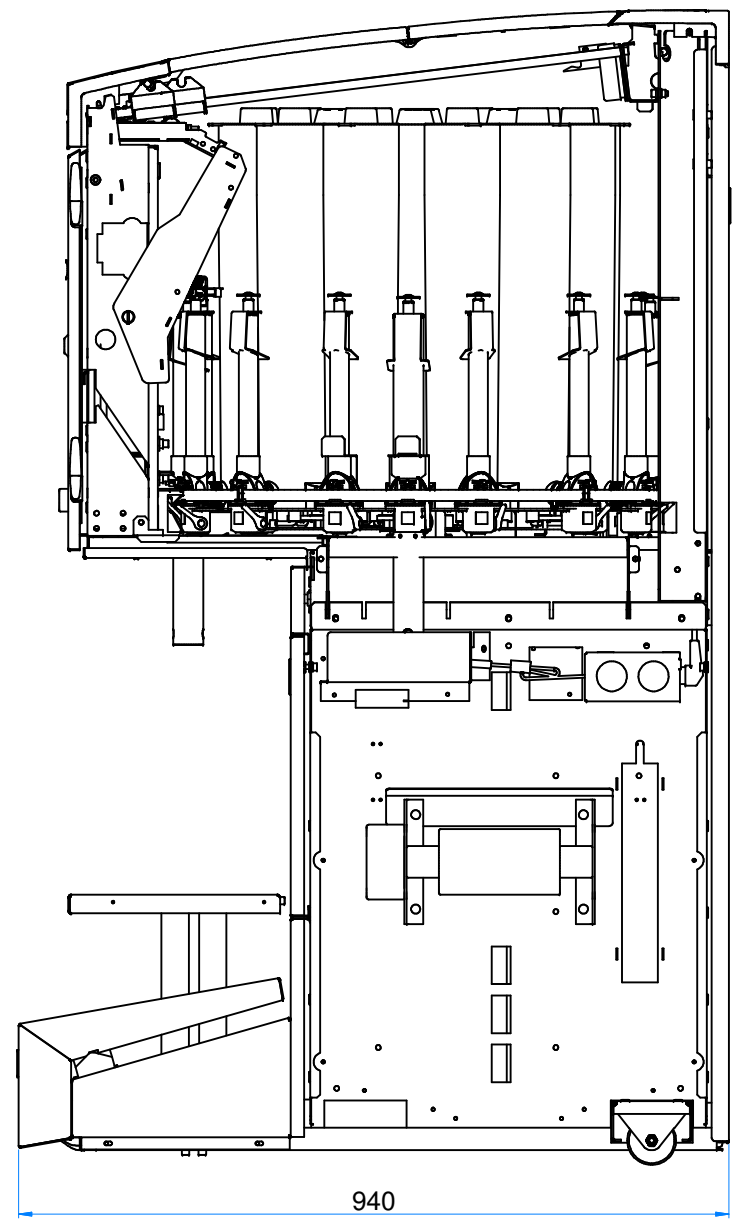
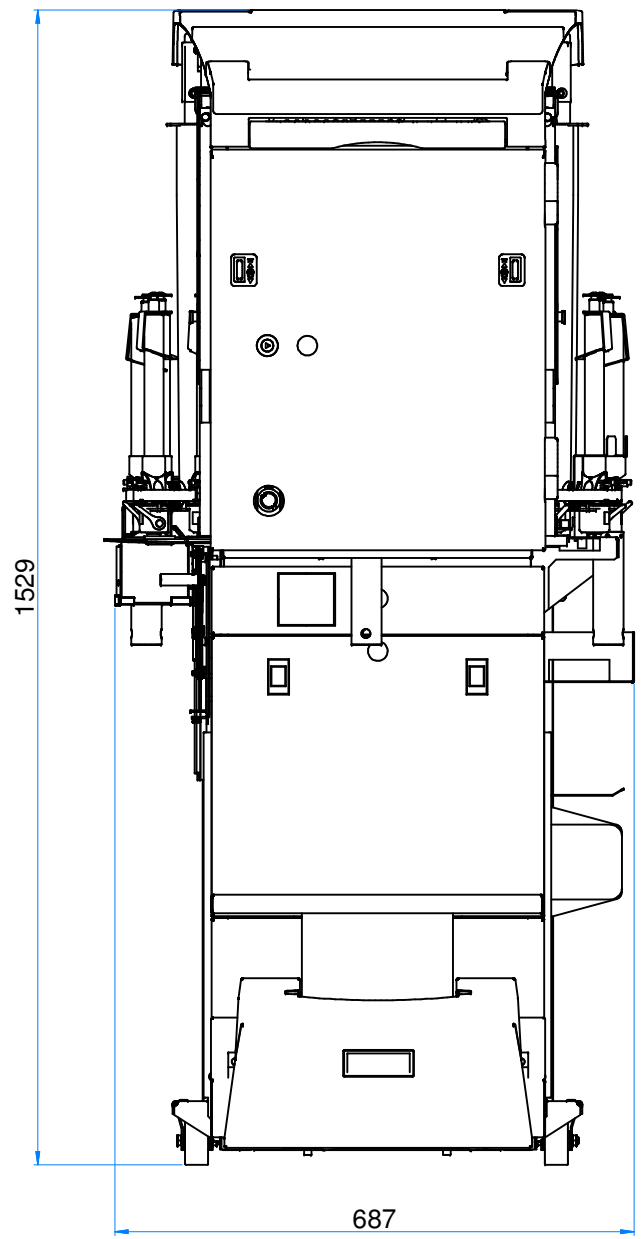

ALL DIMS ACC. TO NEN-ISO 2768 M UNLESS OTHERWISE SPECIFIED 0,5-6 ± 0,1 120-400 ± 0,5 SHORTEST SIDE 50-120 ± 20' 6-30 ± 0,2 400-1000 ± 0,8 < 10 ± 1' 120-400 ± 10' 30-120 ± 0,3 1000-2000 ± 1,2 10-50 ± 30" > 400 ± 5"	CONFIDENTIAL PROPRIETARY MATERIAL. All design, reproduction, manufacturing, use & sales rights of items shown here on or of articles fabricated therefrom are expressly reserved by FAST & FLUID MANAGEMENT		DRAWING ACCORDING TO NEN-ISO 1101 NEN-ISO 406 NEN 3634	Projection
	Size: A2	Unit : mm	Date :2-2-2004	
FAST & FLUID MANAGEMENT THE NETHERLANDS A Unit of IDEX Corporation P.O. Box 220 2170 AE Sassenheim Hulp van Doornweg 51 2171 KZ Sassenheim Telephone +31 (0)252 240 800 Fax +31(0)252 240 880 www.fast-fluid.com	Project :	Drawn :	Assembly partnr:	
Dim. :	Material :	Name:		Partnr: 4900 (Ha200)