

**FAST & FLUID
MANAGEMENT**

*Accutinter 8000
Eurotinter Medium
and Eurotinter Large
simultaneous dispensers*

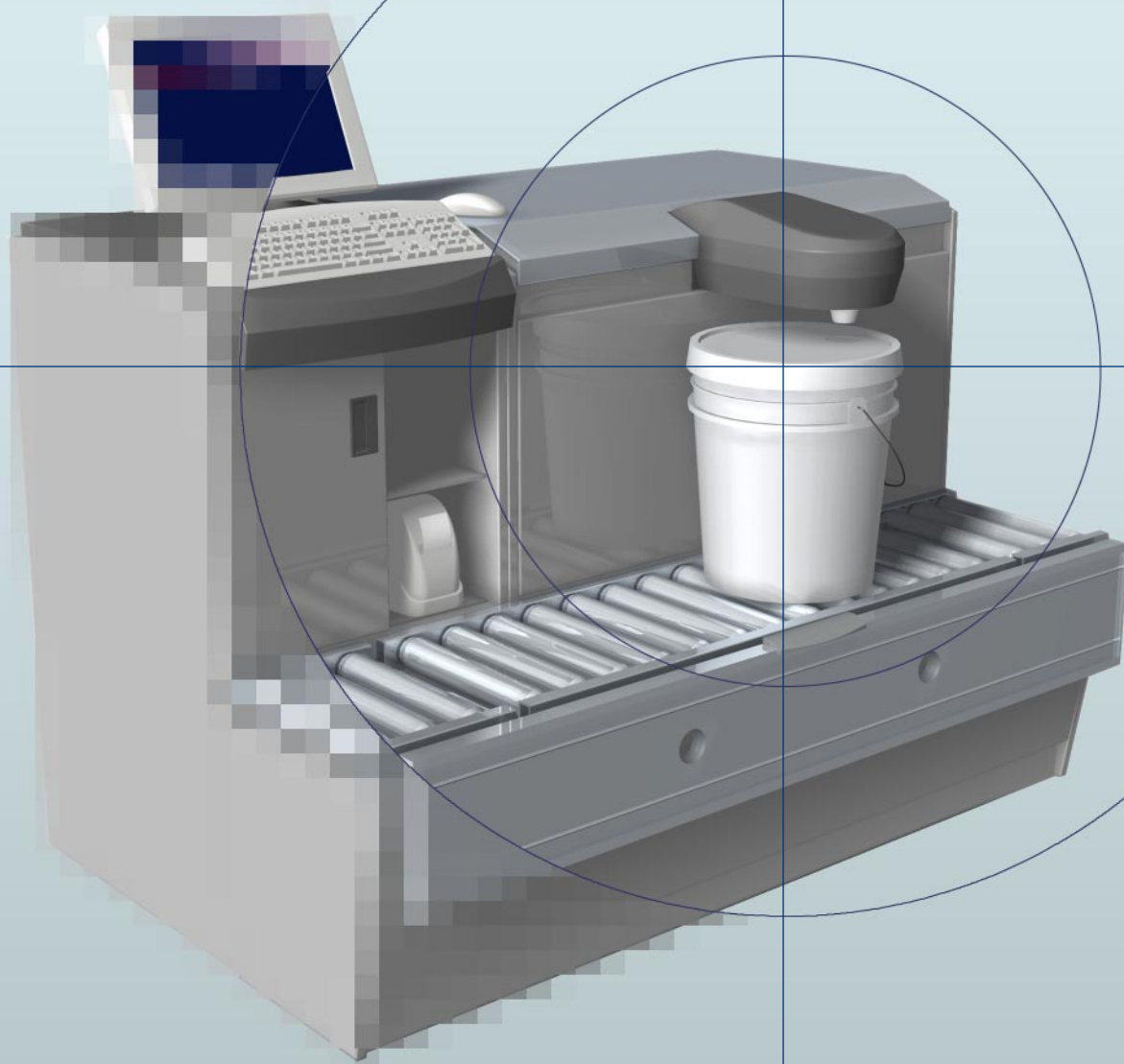

- > **High speed simultaneous dispensing**
- > **Duraflow VX Pump**
- > **Full Ceramic Pump**
- > **Easy refilling and maintenance**

*Accutinter 8000
Eurotinter Medium
Eurotinter Large
simultaneous dispensers*



Eurotinter Large



Eurotinter Medium



Accutinter 8000

Company profile

Fast & Fluid Management is the world leader in dispensing, mixing and tinting equipment for the paint and ink industry. Fast & Fluid Management also supplies dispensing and mixing equipment to many other industries, including the food, chemical, flavoring and cosmetic markets. Product innovation, quality products, special engineered products and customer support have elevated the company to the leading position it enjoys today. We operate in almost all the nations around the globe through our own offices and network of agents. All these operations provide professional, local assistance and services, making Fast & Fluid Management a true partner for your business.

Automatic dispensers

Fast & Fluid Management's automatic dispensers make custom blending easy and flexible. Producing only your immediate requirements and reducing your stock levels by just-in-time delivery; it minimizes waste and ensures an exact color reproduction. You will be able to make any color in any quantity at any moment in time. Flexibility, high accuracy, reliability, ease of operation and minimum maintenance make Fast & Fluid Management's automatic dispensers first choice in many industries. As a result, our equipment can be found in numerous retail environments, service centers and industrial plants worldwide.

Model: Accutinter 8000

The Accutinter 8000 is the first of a new line of Fast & Fluid Management's next generation simultaneous volumetric dispensers for high output environments like dealer shops and depots. A revolutionary breakthrough in simultaneous dispensing is the Duraflow VX Pump used in the Accutinter 8000. This new so-called nutating pump, is the first used in tinting dispensers. With the Duraflow VX Pump the actual pump parts in contact with the product are ceramic, reducing wear to an absolute minimum and enabling the pump to be used with the most abrasive colorants. This means a very low cost of ownership over the lifetime of the dispenser. The Accutinter 8000 is a first step of a modular concept design for up to 32 lines of colorants.

Model: Eurotinter Medium and Eurostile Large

The Eurotinter Medium and Eurotinter Large are part of a modular concept design enabling to size the dispenser to the customer needs from the use in a dealer environment to in-factory batch tinting. The canister modules can be configured from 5,5 liters to 100 liters. The Eurotinter Large can be fitted with automatic refillable canisters coupled to a main tank. Up to 24 lines can be fitted to the Eurotinter family. One of the most spectacular features is the new Full Ceramic Pump, winner of the European Engineering Award 2002. This pump allows you to run a gear pump at the lowest operational costs as all the wear sensitive parts are ceramic. The Eurotinter line is equipped with the Inline Nozzle Closure valve. This innovation ensures a perfect clean valve, which guarantees a perfectly performance of the dispenser at all times.



Full Ceramic Pump

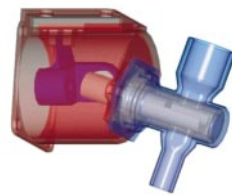

Duraflow VX Pump

CE approved | Patent applied

Specifications on request and subject to change without prior notice